

# Alliance Air Dryer Replacement Cartridge



*Cleansing your brake system from moisture and contamination, the high quality Alliance Air Dryer Cartridge offers you the safety and confidence you need to keep your truck on the road.*

## GENERAL PRODUCT INFORMATION

The Alliance air dryer spin-on replacement cartridge is not a will-fitted or re-engineered product. It uses long-life desiccants and is manufactured with OE components following OE specifications. Alliance air dryer cartridges remove 96% of the moisture and contaminants from the air brake system ensuring the system's effectiveness. This product is new; it has not been remanufactured.

## PART NUMBER CHART

Alliance Part Number	Description	Application
ABP/N10G-R950011	Air Dryer Cartridge	Spin On

## PRODUCT AVAILABILITY

To locate your nearest dealer, please visit [www.freightliner.com](http://www.freightliner.com).

## WARRANTY

Alliance air dryer cartridges are subject to consumption during their normal service life and are routinely replaced during normal maintenance services, and therefore are not covered under aftermarket parts warranty.

## ADDITIONAL INFORMATION

To learn more about Alliance parts, please visit [www.alliancebrandparts.com](http://www.alliancebrandparts.com).

## FEATURES & BENEFITS

- 100% greater water absorption
- Extended desiccant cartridge life
- Improved desiccant crust strength
- Significantly increased tolerance of oil contamination
- The spin-on cartridge allows for convenience, reduced downtime, and easy replacement.
- The compact size allows for effective installation in cramped places.
- It's lightweight, so more freight can be carried.
- It prevents contamination, moisture and corrosion in the system.

## RELATED BUYS

- Air Brake Control Valves
- Air Compressors
- Electronic Leveling Valves
- D2-Governor
- Hydraulic ABS
- Mechanical Leveling Valves
- Replacement Cartridges
- ABS Components

## FREQUENTLY ASKED QUESTIONS

**Is the cartridge only important during winter operation?**

**Answer:** No. Air in an unprotected system is always 100% saturated with water vapor. That means that even a one-degree drop in temperature will cause condensation to occur in the system's valves, lines and reservoirs.

**What is the function of an air dryer cartridge?**

**Answer:** It protects the vehicle's system by drying moisture-laden air before it passes through air reservoirs and into the brake system.

## CROSS-REFERENCE INFORMATION

### PART NUMBERS

Alliance	Arvin Meritor	Bendix	Haldex
ABP/N10G-R950011	TDA/R950011 TDA/R109994	BW/BR950011 BW/5008414 BW/109994	HDX/109994K

## Alliance Cast Brake Drums by ConMet

The Alliance brake drum product line includes some of the industry's fastest moving drums.



### ALLIANCE CAST BRAKE DRUMS – SELECTION GUIDE

Alliance Part Number	Brake Size	Overall Depth	Brake Surface Width	Pilot	Bolt Circle	Bolt Hole Number	Bolt Hole Size	Flange Thickness	Weight	GAWR
ABP/N42A10009830	16.5 X 7	10.56	7.48	8.78	11.25	10	1.00	0.53	112	27,000
ABP/N42A10009920	15 X 4	9.18	4.54	8.78	11.25	10	1.28	0.5	80	14,000
ABP/N42A107193	16.5 X 6	9.74	6.40	8.78	11.25	10	1.28	0.63	109	23,000
ABP/N42A107453	16.5 X 5	9.37	5.31	8.78	11.25	10	1.28	0.5	94	14,700
ABP/N42A107507	15 X 4	8.79	4.66	8.78	11.25	10	1.28	0.5	71	14,000
ABP/N42A107637	16.5 X 8	11.06	8.48	8.78	11.25	10	1.00	0.53	119	26,000
ABP/N42A107638	16.5 X 8.625	11.37	9.00	8.78	11.25	10	1.00	0.62	124	26,000
ABP/N42A107861	15 X 5	9.33	5.30	9.00	275mm	8	1.03	0.5	82	14,000
ABP/N42A107862	15 X 5	9.33	5.30	8.78	11.25	10	1.28	0.5	82	14,000
ABP/N42A107863	15 X 5/6	10.28	7.02	8.78	11.25	10	1.00	0.5	95	12,000
ABP/N42A107864	15 X 5/6	10.28	7.02	9.00	275mm	8	1.00	0.5	92	12,000
ABP/N42A107865	15 X 8.625	11.9	9.21	9.00	275mm	8	1.00	0.5	109	17,000
ABP/N42A107866	15 X 8.625	11.9	9.21	8.78	11.25	10	1.00	0.5	109	17,000
ABP/N42A107875	16.5 X 7	10.56	7.48	9.00	275mm	8	1.00	0.53	112	27,000
ABP/N42A107885	16.5 X 7	10.3	7.28	8.78	11.25	10	1.00	0.53	110	27,000
ABP/N42A107902	15 X 4	9.18	4.54	9.00	275mm	8	1.00	0.5	80	14,000
ABP/N42A107904	16.5 x 7	10.56	7.48	9.00	11.25	10	0.81	0.53	112	27,000

#### FEATURES & BENEFITS

- Alliance brake drums are cast iron, machined balanced and FMVSS approved.
- Tru-Turn technology on **ABP/N42A10009830** and **ABP/N42A10009920**.

#### PRODUCT AVAILABILITY

To locate your nearest dealer, please visit [www.daimler-trucksnorthamerica.com](http://www.daimler-trucksnorthamerica.com).

#### TOP SELLERS

**ABP/N42A10009830**      **ABP/N42A107866**  
**ABP/N42A10009920**      **ABP/N42A107193**  
**ABP/N42A107507**      **ABP/N42A107638**  
**ABP/N42A107885**

#### WARRANTY

Alliance Parts are backed by a one-year unlimited mile warranty, with coverage available throughout North America.

## ALLIANCE BRAKE DRUM CROSS REFERENCE

Webb Crossover		Gunito Crossover		Meritor Crossover	
Webb Part Number	Alliance Part Number	Gunito Part Number	Alliance Part Number	Meritor Part Number	Alliance Part Number
61528B	ABP/N42A107507	2769X	ABP/N42A107904	85123399002	ABP/N42A107193
61958B	ABP/N42A107864	3141BX	ABP/N42A107875	85122550002	ABP/N42A107904
61992F	ABP/N42A107866	3141X	ABP/N42A107904	85123207002	ABP/N42A10009830
61999F	ABP/N42A107865	3402X	ABP/N42A107885	85123409002	ABP/N42A107875
62671F	ABP/N42A107193	3600AX	ABP/N42A10009830	85123465002	ABP/N42A107863
65543B	ABP/N42A107902	3687X	ABP/N42A107193	85123570002	ABP/N42A107637
65554B	ABP/N42A107862	3721AX	ABP/N42A107507	85123254002	ABP/N42A107507
66800B	ABP/N42A107637	3726X	ABP/N42A107164	85123365002	ABP/N42A107885
66854F	ABP/N42A107638	3741X	ABP/N42A107902		
66864F	ABP/N42A107150	3744AX	ABP/N42A107865		
66873F	ABP/N42A107885	3744X	ABP/N42A107866		
66875F	ABP/N42A107875	3753AX	ABP/N42A107864		
66895B	ABP/N42A107904	3753X	ABP/N42A107863		
61998B	ABP/N42A107865	3758X	ABP/N42A107453		
66864B	ABP/N42A10009830	3774AX	ABP/N42A107861		
		3774X	ABP/N42A107862		
		3807X	ABP/N42A107638		
		3782X	ABP/N42A107637		
		3800X	ABP/N42A10009920		

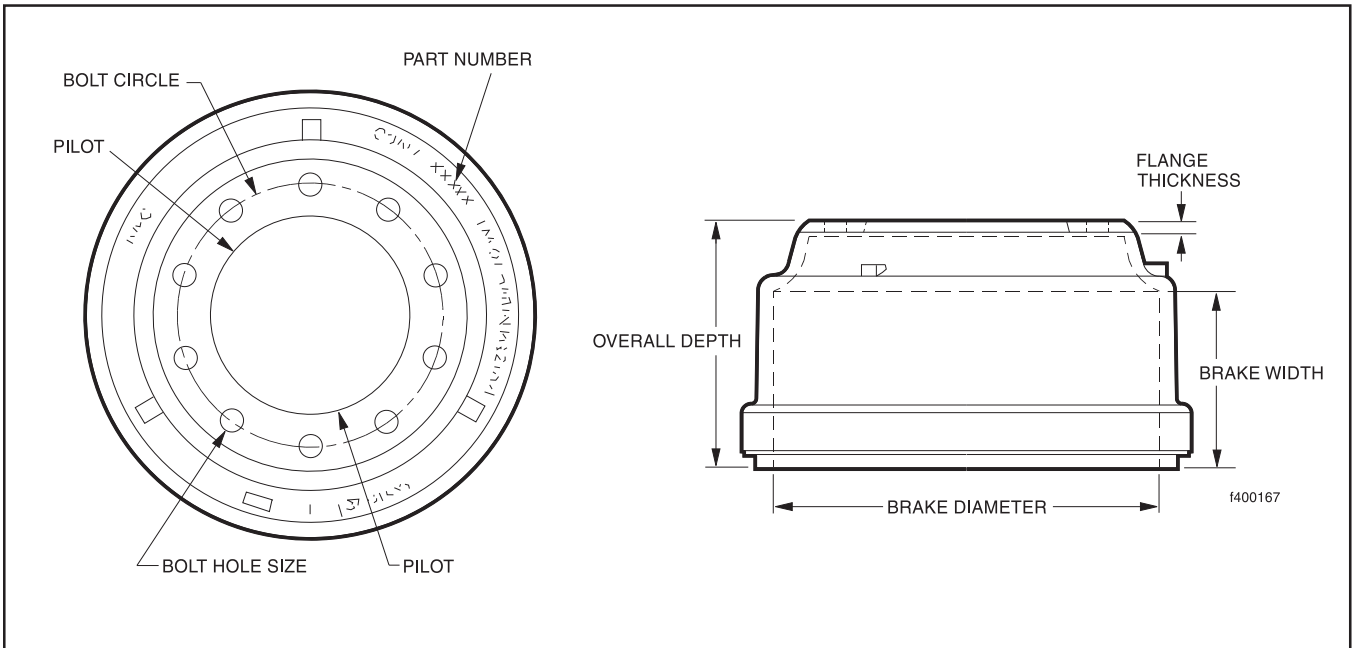



## Alliance Remanufactured Brake Shoes & Brake Kits



Top quality brake shoes with linings available in either the Premium 20 for 20,000# axle applications or the Premium 23 for 23,000# axle applications.

### GENERAL PRODUCT INFORMATION

#### ALLIANCE BRAKE SHOES

Alliance brake shoes are manufactured to the strictest quality standards—which means you don't have to trade quality for value.

#### ALLIANCE BRAKE LININGS

##### Premium 20

Premium 20 has been engineered to Freightliner LLC specifications to deliver superior stopping power compared to similarly classed linings used in 20,000# axle applications.

Premium 20 easily passes the F.M.V.S.S. #121 dynamometer testing standard with a type 30 air chamber and a 5.5" slack adjuster, in combination with a 20.8" tire rolling radius. Premium 20 has undergone extensive laboratory and field testing. Results from these tests show that Premium 20 demonstrates ample stopping power, complemented by solid fade and recovery characteristics.

##### Premium 23

Premium 23 has been engineered for the price-sensitive premium grade brake lining buyer looking for block to handle demanding brake applications. This material is ideally suited for heavier-than-normal hauling operations such as liquid tanker, grain, cement, or refuse collection. Premium 23 is also a good choice for low powered brake systems that require a more aggressive lining.

Premium 23 easily passes the F.M.V.S.S. #121 dynamometer testing standard with a type 30 air chamber and a 5.5" slack adjuster, in combination with a 20.8" tire rolling radius. Premium 23 has undergone extensive laboratory and field testing to confirm its ample stopping power in combination with positive fade and recovery characteristics.

### PRODUCT AVAILABILITY

To locate your nearest dealer, please visit [www.freightliner.com](http://www.freightliner.com).

### PART NUMBERS

Alliance Part Number	Description
<b>BRAKE SHOES</b>	
ABP/RB1308E-20PREM	1308 Eaton Exchange Shoe with Premium 20 lining
ABP/RB1308Q-20PREM	1308DQ Exchange Shoe with Premium 20 lining
ABP/RB1443E-20PREM	1443E Exchange Shoe with Premium 20 lining
ABP/RB4311E-20PREM	4311 Eaton Exchange Shoe with Premium 20 lining
ABP/RB4505LG-23PREM	4505A Lucas Girling with Premium 23 lining
ABP/RB4515Q-20PREM	4515 Q Exchange Shoe with Premium 20 lining
ABP/RB4515Q-23PREM	4515 Q Exchange Shoe with Premium 23 lining
ABP/RB4702Q-20PREM	4702 Q Exchange Shoe with Premium 20 lining
ABP/RB4707Q-20PREM	4707 Q Exchange Shoe with Premium 20 lining
ABP/RB4707Q-23PREM	4707 Q Plus Exchange Shoe with Premium 23 lining
ABP/RB4709E2-20PREM	4709 Eaton Exchange Shoe with Premium 20 lining
ABP/RB4709E2-23PREM	4709E2 Eaton Exchange Shoe with Premium 23 lining
<b>BRAKE KITS</b>	
ABP/RK1308E-20PREM	1308E Eaton Exchange Kit with Premium 20 lining
ABP/RK1308Q-20PREM	1308 Q Exchange Kit with Premium 20 lining
ABP/RK1443E-20PREM	1443E Eaton Exchange Kit with Premium 20 lining
ABP/RK4311E-20PREM	4311 Eaton Exchange Kit with Premium 20 lining
ABP/RK4515Q-20PREM	4515 Q Exchange Kit with Premium 20 lining
ABP/RK4515Q-23PREM	4515 Q Exchange Kit with Premium 23 lining
ABP/RK4515X-20PREM	4515 XEM3 Exchange Kit with Premium 20 lining
ABP/RK4702Q-20PREM	4702 Q Exchange Kit with Premium 20 lining
ABP/RK4707Q-20PREM	4707 Q Exchange Kit with Premium 20 lining
ABP/RK4707Q-23PREM	4707 Q Exchange Kit with Premium 23 lining
ABP/RK4709E2-20PREM	4709 Eaton Exchange Kit with Premium 20 lining

## FEATURES & BENEFITS

### Brake Linings/Premium 20 Features

- Cost effective option for price sensitive buyers
- Asbestos-free, organic friction material
- Designed for 20,000# axle applications
- Dependable stopping power
- Ideal for general freight hauling
- Available in a wide range of FMSI numbers

### Brake Linings/Premium 23 Features

- Cost effective option for price sensitive buyers
- Combination block using organic friction materials
- Designed for 23,000# axle applications
- Dependable stopping power
- Ideal for severe duty hauling

## WARRANTY

Alliance parts are backed by a one-year unlimited mile warranty, with coverage available throughout North America.

## ADDITIONAL INFORMATION

To learn more about Alliance parts, please visit [www.alliancebrandparts.com](http://www.alliancebrandparts.com).

## BRAKE APPLICATION GUIDE

Axle Load	195 A/L	180 A/L	165 A/LT	144 A/L
	Type 30 Chamber x 6.5 " Slack	Type 30 Chamber x 6.0 " Slack	Type 30 Chamber x 5.5 " Slack	Type 24 Chamber x 6.0 " Slack
14,000	—	—	—	20 PREM
15,000	—	—	20 PREM	20 PREM
16,000	—	—	20 PREM	20 PREM
17,000	—	20 PREM	20 PREM	20 PREM
18,000	—	20 PREM	20 PREM	20 PREM
19,000	20 PREM	20 PREM	20 PREM	23 PREM
20,000	20 PREM	20 PREM	20 PREM	23 PREM
21,000	20 PREM	20 PREM	23 PREM	23 PREM
22,000	20 PREM	23 PREM	23 PREM	—
23,000	23 PREM	23 PREM	23 PREM	—
24,000	23 PREM	23 PREM	—	—
25,000	23 PREM	—	—	—

## FRICTION APPLICATION GUIDE

	20,000# Axle Load	23,000# Axle Load or Severe Duty
Tandem Axle Tractor Trailer	20 PREM	—
Double	20 PREM	—
Flatbed	20 PREM	—
Beverage	20 PREM	—
School Bus	20 PREM	—
Refuse Truck	—	23 PREM
Mixer (Tandem Axle)	—	23 PREM
Tandem Dump	—	23 PREM
Tanker	—	23 PREM

## FREQUENTLY ASKED QUESTIONS

### Why Buy Alliance Shoes?

- Premium quality at an affordable price
- Available in a wide range of FMSI numbers
- Quality procedures ensure QS90000/ISO9001 practices are followed
- Offered in either separate shoes or kits with hardware
- Shoes are coined to ensure consistent top quality

## WHEN YOU NEED MORE INFORMATION...

The following literature is available to you at your local dealer.

Catalog Number	Description
CS/PSM-B-426	Alliance Brake Shoe Brochure (8/06MCD)



## Alliance Remanufactured Air Compressors



*Efficient, higher capacity and reliable compressors from Alliance to meet stricter braking requirements and other supported air operated accessories.*

### GENERAL PRODUCT INFORMATION

The air compressor is the source of energy for the air brake system. It is driven by the vehicle's engine, either by belt or the drive gear.

### PART NUMBER CHART

Alliance Part Number	Description	Application
ABP/RC10-5004082	Air Compressor	13CFM TF550 Adaptorless
ABP/RC10-5004083	Air Compressor	16CFM TF750 Adaptorless
ABP/RC10-5010823	Air Compressor	16CFM BA921 (EGR Application)
ABP/RC10-65672	Air Compressor	13CFM TF550 Adaptor
ABP/RC10-65671	Air Compressor	16.5CFM TF750 Adaptor

### COMPETITIVE CROSS-REFERENCE CHART

#### PART NUMBERS

Alliance	Detroit Diesel	Bendix	Bendix Reman	Haldex
ABP/RC10-5004082	DDE/R23522122	BW/5004082	BW/R5004188	HDX/109429X
ABP/RC10-5004083	DDE/R23522123	BW/5004083	BW/R5004187	HDX/109430X
ABP/RC10-5010823	DDE/R23532823	BW/5010823	N/A	HDX/5010824X
ABP/RC10-65672	DDE/R23505234	BW/65672	BW/R107622	HDX/107622X
ABP/RC10-65671	DDE/R23505235	BW/65671	BW/R107623	N/A

### PRODUCT AVAILABILITY

To locate your nearest dealer, please visit [www.freightliner.com](http://www.freightliner.com).

### WARRANTY

Alliance Parts are backed by a one-year unlimited mile warranty, with coverage available throughout North America.

## FOCUS ON QUALITY

- Remanufactured by Master, Fully-Trained, Technicians,
- Using State-of-the-Art Cellular Manufacturing Process,
- In ISO 9001 Certified Facilities,
- With Dedicated Assembly and Quality Assurance Stations,
- Under a Controlled Manufacturing Process.

## ADDITIONAL INFORMATION

To learn more about Alliance parts, please visit [www.alliancebrandparts.com](http://www.alliancebrandparts.com).

## FEATURES & BENEFITS

- 100% replacement of pistons
- 100% replacement of gaskets and bearings
- 100% size inspection of all critical components
- 100% pressure test of cooling system
- 100% computer controlled testing of finished product with test data retention
- Superior surface finish from hone and brush procedure
- No-hassle core criteria



## Alliance Remanufactured Air Dryer Cartridge



*The Alliance AD9 remanufactured replacement air dryer provides the same high quality brake system protection users have depended on since the system was new, and can be used as a replacement element for standard and extended purge AD9 air dryers.*

### GENERAL PRODUCT INFORMATION

Air dryers are in line filters between the air compressor and storage reservoirs that remove both liquid and vapor from compressor discharge air before it reaches the reservoir, resulting in only clean dry air being supplied to the air system. The recommended replacement cycle is every two years during normal service.

**HIGH MOVERS** The AD9 model element is the top selling Bendix air dryer cartridge.

Alliance Part Number	Description	Application
ABP/R42B-107794X	Alliance AD9 remanufactured replacement air dryer desiccant cartridge	Replacement element for standard and extended purge AD9 air dryers

### COMPETITIVE CROSSOVER

The ABP/R42B-107794X is a service replacement for the following part numbers:

<b>BW/R107794</b>	Remanufactured Bendix AD9 Air Dryer Cartridge
<b>BW/107796</b>	New Bendix AD9 Air Dryer Cartridge
<b>HXD/107794X</b>	Remanufactured Haldex AD9 Air Dryer Cartridge

### RELATED SERVICE ITEMS

#### D2-Governor

- TDA/RKN18530 – D2-Governor 1 each
- TDA/RKN18536 – D2-Governor 6 Pack

Correct operation of the D2-Governor is essential for controlling proper air dryer purge, necessary for regeneration. Proper regeneration significantly extends dryer cartridge life and assures optimum performance.

### PRODUCT AVAILABILITY

To locate your nearest dealer, please visit [www.freightliner.com](http://www.freightliner.com).

### WARRANTY

Alliance Parts are backed by a one-year unlimited mile warranty, with coverage available throughout North America.

## FREQUENTLY ASKED QUESTIONS

**Question** Is the same cartridge kit used for standard and extended purge dryers?  
**Response** Yes.

**Question** Is the dryer cartridge only important during winter operation?  
**Response** No, air in an unprotected brake system **is always** 100% saturated with water vapor. This means that even a one-degree drop in air temperature will cause condensation to form in the system's valves, lines, and reservoirs. Winter operations provide opportunity for this moisture to freeze; however, the moisture itself is always damaging to the air system.

**Question** **Is it difficult to replace the service cartridge element?**  
**Response** No. The service cartridge element is self contained for easy replacement at any Freightliner Group repair facility.

## FEATURES & BENEFITS

- Environmentally friendly, the recycling of the desiccant cartridge prevents material that is oil soaked from being disposed of in the environment.
- This product is equivalent in performance and quality when compared to the genuine AD9 remanufactured air dryer cartridge.
- The Alliance air dryer cartridge is brought to you at an attractive price that brings you maintenance cost savings reducing your overall cost per mile of operation.

## CORE INFORMATION

Alliance AD9 remanufactured air dryers are sold remanufactured exchange.

For full core credit, your core will be visually inspected to determine that the canister is not bent or dented, and to assure threads are not crossed-threaded or stripped.

## ADDITIONAL INFORMATION

To learn more about Alliance parts, please visit [www.alliancebrandparts.com](http://www.alliancebrandparts.com).

## Alliance Spring Brakes

*You're assured of the highest quality spring brake when you purchase Alliance spring brakes.*

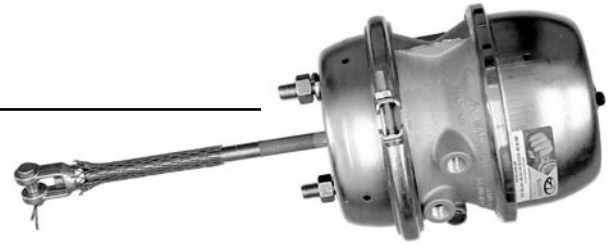

### GENERAL PRODUCT INFORMATION

- Alliance spring brakes are designed to provide years of safe, dependable service for parking or emergency braking applications. These spring brakes and service chambers feature rugged construction, using heavy gauge steel brake housings and steel components throughout.
- Alliance spring brakes are manufactured by an ISO9001: 2000 certified company that manufactures nearly all of the brake components in house. They stamp, form and assemble our housings and then perform extensive testing to ensure the brakes will perform as designed.
- The leading cause of premature spring brake failure is mis-alignment of the power spring or push rod. Alliance spring brakes are designed to solve these common problems, helping to ensure delivery of a long service life without maintenance problems.
- Alliance spring brakes will help reduce maintenance costs by providing greater corrosion resistance and eliminating component failure.

### WARRANTY

Alliance Parts are backed by a one-year unlimited mile warranty, with coverage available throughout North America.

### PRODUCT AVAILABILITY

To locate your nearest dealer, please visit [www.daimler-trucksnorthamerica.com](http://www.daimler-trucksnorthamerica.com).

### ADDITIONAL INFORMATION

To learn more about Alliance parts, please visit: [www.alliancebrandparts.com](http://www.alliancebrandparts.com).

### FEATURES & BENEFITS

- **Chrome Silicon Steel Main Spring**—Epoxy coated for corrosion protection. A unique shot peening process is applied which dramatically extends the life of the spring.
- **Guided Spring Pressure Plate**—Keeps pressure plate centered preventing side forces which cause diaphragm sidewall and seal wear.
- **Mechanical Sure Crimp Seal**—A special crimping method ensures a no-guess diaphragm seal and allows a low profile without clamp interference.
- **Chrome Plated Internal Push Rod**—Chrome plated steel ground to just the right finish—Rough Machine Surface (32RMS)—to retain lubrication and prevent premature seal wear. Hard chrome for wear resistance and corrosion protection.
- **Heavy Duty Premium Diaphragms**—Synthetic blended rubber for superior resistance against abrasion and fatigue cracking. Tested to 1,000,000 cycles.
- **Music Wire Return Springs**—Made from pre-galvanized wire for maximum corrosion protection. Low stress barrel configuration.
- **Heavy 10-Gauge Non-pressure Housing**—Designed for bracket contact at the crucial outer edges. Mounting studs are reinforced to prevent pull out.
- **Friction Welded Push Rod**—Provides a total attachment to the plate preventing the rod from breaking loose.

<b>PART NUMBER REFERENCE CHART</b>			
Part Number	Description	Part Number	Description
<b>PIGGYBACK CHAMBERS: Priced per. Min order qty 2.</b>		<b>SERVICE CHAMBERS (CONT)</b>	
ABP/N42A-12024PD	2024	ABP/N42A-24SCD	24" Boxed-With Clevis
ABP/N42A-12424PD	2424	ABP/N42A-24SCND	24" Boxed-No Clevis
ABP/N42A-12430PD	2430	ABP/N42A-24SC3D	24" 3" Stroke-Boxed-With Clevis
ABP/N42A-13030PD	3030	ABP/N42A-24SC3ND	24" 3" Stroke-Boxed-No Clevis
ABP/N42A-13036PD	3036	ABP/N42A-30SCD	30" Boxed-With Clevis
ABP/N42A-13636PD	3636	ABP/N42A-30SCND	30" Boxed-No Clevis
<b>PIGGYBACK KITS</b>		<b>COMPONENT PARTS</b>	
ABP/N42A-24PBKD	2424 2.5" Stroke Kit*	ABP/N42A-10026AD	1/2" Clevis Assembly
ABP/N42A-30PBKD	3030 2.5" Stroke Kit*	ABP/N42A-10026BD	5/8" Clevis Assembly
ABP N42A 30PBK3D	3030 3" Stroke Kit*	ABP/N42A-24013AD	24" Service Brake Push Rod
<b>SPRING BRAKES</b>		<b>DIAPHRAGMS</b>	
ABP/N42A-12024CD	2024 Combo-Boxed-With Clevis	ABP/N42A-D09000D	9" Low-Temp Diaphragm
ABP/N42A-42024CD	2024 Combo-Boxed-No Clevis	ABP/N42A-D12000D	12" Low-Temp Diaphragm
ABP/N42A-12424CD	2424 Combo-Boxed-With Clevis	ABP/N42A-D16000D	16" Low-Temp Diaphragm
ABP/N42A-42424CD	2424 Combo-Boxed-No Clevis	ABP/N42A-D20000D	20" Low-Temp Diaphragm
ABP/N42A-12430CD	2430 Combo-Boxed-With Clevis	ABP/N42A-D24000D	24" Low-Temp Diaphragm
ABP/N42A-42430CD	2430 Combo-Boxed-No Clevis	ABP/N42A-D24002D	24" Long Stroke Low-Temp Diaphragm
ABP/N42A-12430C3D	2430 Combo-3" Stroke-Boxed-With Clevis	ABP/N42A-D24003D	24" Low-Temp Diaphragm
ABP/N42A-42430C3D	2430 Combo-3" Stroke-Boxed-No Clevis	ABP/N42A-D30000D	30" Low-Temp Diaphragm
ABP/N42A-13030CD	3030 Combo-Boxed-With Clevis	ABP/N42A-D30003D	30" 3" Stroke Low-Temp Diaphragm
ABP/N42A-43030CD	3030 Combo-Boxed-No Clevis	ABP/N42A-D36000D	36" 3" Stroke Low-Temp Diaphragm
ABP/N42A-13030C3D	3030 Combo-3" Stroke-Boxed-With Clevis		
ABP/N42A-43030C3D	3030 Combo-3" Stroke-Boxed-No Clevis		
ABP/N42A-13036CD	3036 Combo-Boxed-With Clevis		
ABP/N42A-43036CD	3036 Combo-Boxed-No Clevis		
ABP/N42A-13636CD	3636 Combo-Boxed-With Clevis		
ABP/N42A-43636CD	3636 Combo-Boxed-No Clevis		
<b>SERVICE CHAMBERS</b>			
ABP/N42A-12SCD	12" Boxed-With Clevis		
ABP/N42A-12SCND	12" Boxed-No Clevis		
ABP/N42A-16SCD	16" Boxed-With Clevis		
ABP/N42A-16SCND	16" Boxed-No Clevis		
ABP/N42A-20SCD	20" Boxed-With Clevis		
ABP/N42A-20SCND	20" Boxed-No Clevis		

\* Kit contains piggyback chamber, band clamp, and diaphragm.